

VGCP3-DS

Double Sided Adjustable
Self-Service Protector w/ Shelf

Item No: _____

Qty: _____

Length (O.A.): _____

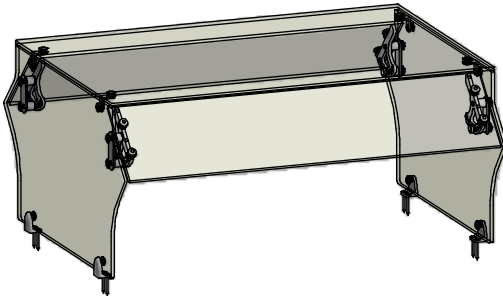

1 - Section Unit
Up to 62" O.A. length max.

SPECIFICATIONS:

Double Sided Adjustable Self-Service Food Protector w/ Shelf.

All component hardware CNC machined in 6061-T6 aluminum to $\pm .005"$.

All glass front panels are 3/8" clear tempered with ground & polished edges and meet ANSI Z97.1

All glass top panels are 3/8" clear tempered with ground & polished edges and meet ANSI Z97.1

All glass end panels are 3/8" clear tempered with ground & polished edges and meet ANSI Z97.1

specifications for safety performance and ASTM C1048-04 specifications for heat treated glass.

All hardware supplied in a satin clear anodized aluminum finish.

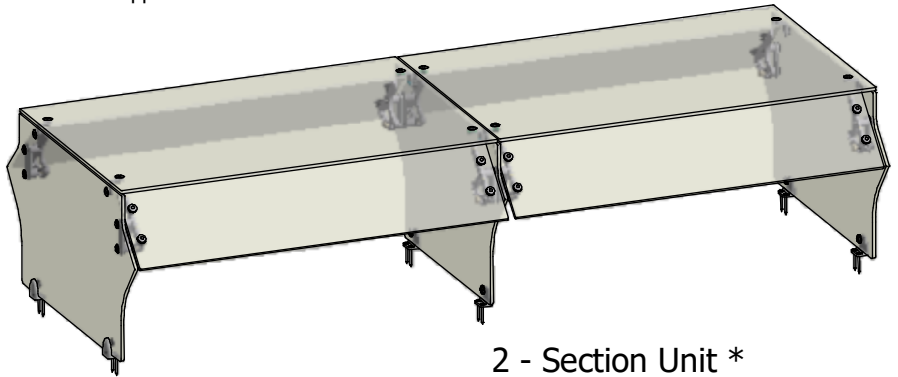

2 - Section Unit *
Up to 124" O.A. length, (2) 62" sections max.

* Can Be Configured In Multiple Sections

FINISH:

- Clear Anodized Aluminum (std.)
 - Anodized Aluminum Custom Color
- _____ (Contact Factory) _____

GLASS:

- Clear (std.)
- Frosted

OPTIONS:

- VG 12V LED Light
 - Hatco Strip Warmer
- Model # _____

MOUNT:

- Conceal Mount
- Surface Mount

- Overall Dimensions -

L / L1 - 62" Max
L2 - 124" Max

